

ROLLED CURB AND GUTTER

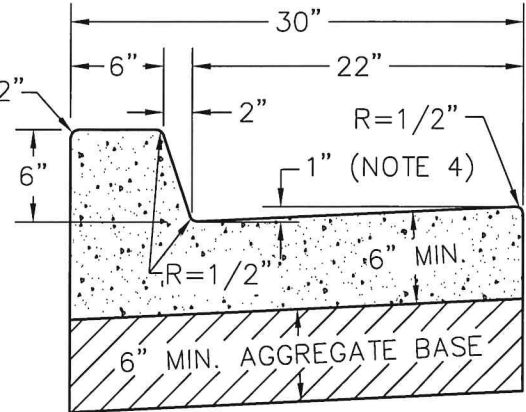

VERTICAL CURB AND GUTTER

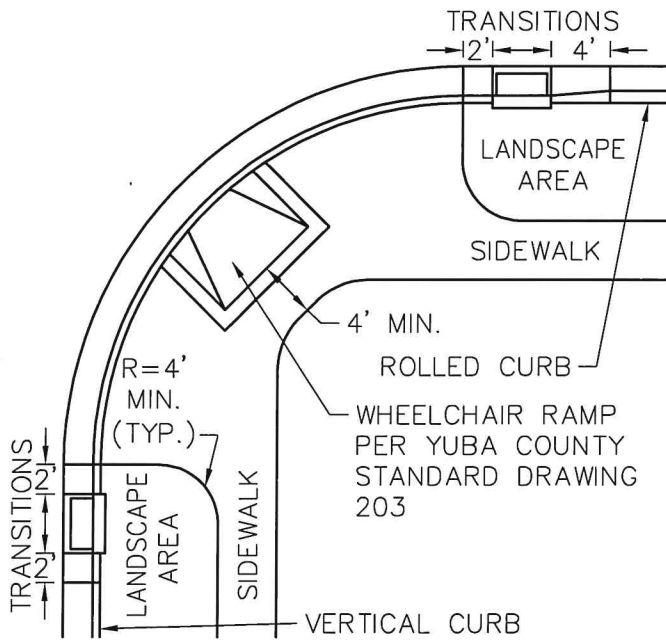

DETACHED SIDEWALK PLAN VIEW

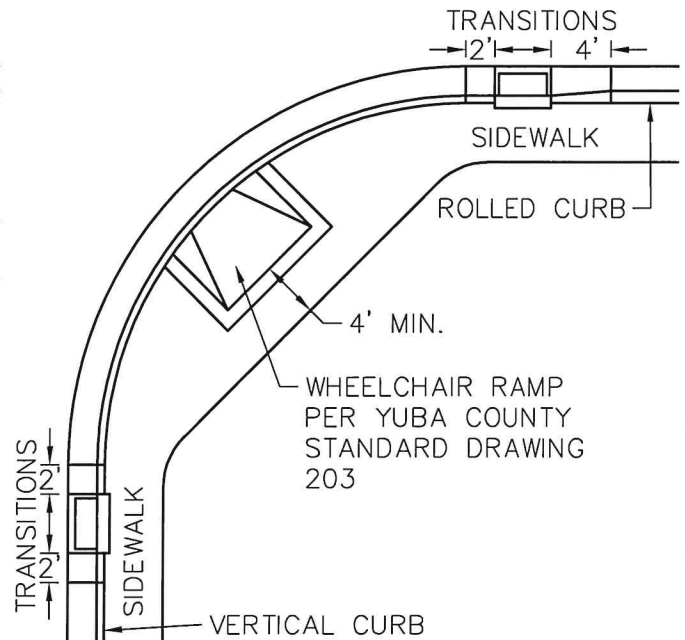

ATTACHED SIDEWALK PLAN VIEW

NOTES:

1. CURB, GUTTER AND SIDEWALK SHALL BE CONSTRUCTED OF CLASS "B" CONCRETE IN ACCORDANCE WITH CALTRANS STANDARD SPECIFICATIONS.
2. ALL CURB GUTTER AND SIDEWALK SHALL HAVE A BROOM FINISH.
3. VERTICAL CURB AND GUTTER TO BE USED AT ALL CURB RETURNS WITH A 1/2" EXPANSION JOINT AT BOTH ENDS.
4. GUTTER PAN CROSS SLOPE NOT TO EXCEED 5% MAXIMUM, OR BE LESS THAN 4% MINIMUM.
5. AGGREGATE BASE SUBGRADE TO BE COMPACTED TO MINIMUM OF 95% RELATIVE COMPACTION.

YUBA COUNTY DEPARTMENT OF PUBLIC WORKS	
CURB AND GUTTER DETAILS	
 APPROVED BY:	4/1/20 DATE:
201	